



MyDro 50 Node (M54)

Installation Manual



Warnings and Notices

The MyDro 54 is rated Class 1 Division 2 non-incendive when powered by its internal battery pack.

- **WARNING: EXPLOSION HAZARD. DO NOT REMOVE OR REPLACE COMPONENTS UNLESS POWER HAS BEEN DISCONNECTED OR THE AREA IS FREE OF IGNITABLE CONCENTRATIONS. AVERTISSEMENT : RISQUE D'EXPLOSION . NE PAS RETIRER OU REMPLACER LES COMPOSANTS QUE L'ALIMENTATION EST DÉBRANCHÉ OU ZONE EST LIBRE DE CONCENTRATIONS IGNITIBLE.**
- **WARNING – EXPLOSION HAZARD.** Substitution of components may impair suitability for Class I, Division 2.
AVERTISSEMENT - RISQUE D'EXPLOSION. La substitution de composants peut rendre ce matériel inacceptable pour les emplacements de classe I, division 2.
- **WARNING – EXPLOSION HAZARD.** Do not disconnect while circuit is live unless area is known to be nonhazardous.
AVERTISSEMENT - RISQUE D'EXPLOSION. Ne débranchez pas lorsque le circuit est en direct , sauf si la zone est connue pour être nonhazardous.
- **WARNING – All wiring methods must be in accordance with the NEC.**
AVERTISSEMENT - Toutes les méthodes de Essorez doivent être en conformité avec la NEC.
- **WARNING - EXPLOSION HAZARD.** Do no remove or replace while circuit is live unless the area is free of ignitable concentrations.
AVERTISSEMENT - RISQUE D'EXPLOSION. Ne pas enlever ou remplacer pendant que le circuit est vivant à moins que la zone soit exempt de concentrations ignitibles.
- **WARNING – EXPLOSION HAZARD.** Do not remove or replace lamps, fuses, or plug-in modules (as applicable) unless power has been disconnected or the area is free of ignitable concentrations.
AVERTISSEMENT - RISQUE D'EXPLOSION. Ne retirez ni ne remplacez les lampes, les fusibles ou les modules enfichables (le cas échéant) à moins que l'alimentation ait été coupée ou que la zone soit exempte de concentrations inflammables.

Contents

Warnings and Notices	2
Specifications	5
Side view	6
Bottom view	6
Connections and Components	7
Status LED	7
Error LED	7
Check-in Button	7
MyDro 54 Internal Components	7
Sensor Connections	8
Analog Input.....	8
4–20mA Wiring Diagram	8
0–5V Wiring Diagram.....	9
Digital Inputs	9
Relay Output.....	10
Expansion Card	10
Power Options	11
Lithium Battery Pack (4DPak).....	11
Internal Lithium Battery Replacement.....	11
Mounting and Care	11
Test the Installation	12
Site Commissioning	13
Confirm Paperwork and Credentials	13
Log into 123SCADA Web Portal	13
Support	16
Webinar	16
Video Demonstrations.....	16
Documentation	16
LinkedIn	16
X (Formerly Twitter).....	16



The MyDro 54 is a self-contained device that provides sensor readings over an LTE-M1 cellular network.

- Powers attached analog (4–20mA / 0–5V) sensor and cellular modem with internal battery.
- Dual digital inputs report state, total counts, and input frequency.
- SPDT latching relay for local on/off control.
- Configurable from the Mission Communications web portal 123SCADA.com that also provides for data visualization, trends, reports, and alarms.
- Compact and simple to install and maintain.
- Internal backlog of a minimum of 200,000 data points in the event of loss of signal. Backlog will be automatically sent when the MyDro 50 reconnects.
- Class 1 Division 2 certified.

Specifications

Enclosure Size and Weight	7.1in tall × 4.6in diameter, 1lb.
Power Source	Internal lithium battery pack.
Temperature Rating	-40°C to +85°C
MyDro 54 SIM Slot	4FF Nano SIM card
MyDro 54 Local ConfigPort	Standard micro-USB connector.
MyDro 54 Analog Input	Three analog inputs (one built in and two on the expansion card) including 3Vdc/18Vdc, (selectable) to attached 4–20mA / 0–5Vdc sensor.
MyDro 54 Digital Inputs	Three digital inputs (two built in and one on the expansion card). Dry Contact or 30 Volts Max (push-pull), 2kHz max. Capable of reporting on state change.
MyDro 54 Relay Output	Latching relay. 2A @ 30VDC, 0.3A @ 110VDC, 0.5A @ 125VAC.
MyDro 54 Sensor Power Output	Selectable 13Vdc / 18Vdc. 60mA max power output.
Compliance	<ul style="list-style-type: none">• Contains FCC ID: 2ANPO00NRF9160 and IC ID: 24529-NRF9160.• PTCRB and Verizon network certified.• Certified for use in Class I, Division 2, Groups A, B, C, D areas. Temperature Code T5 EXi [EXi]• [UL 121201:2017 Ed.9+R:26Aug2019], [CSA C22.2#213:2017 Ed.3+U1;U2]• IEC 62638-1:2014 (2nd Ed), EN 62368-1:2014+A11:2017

Side view

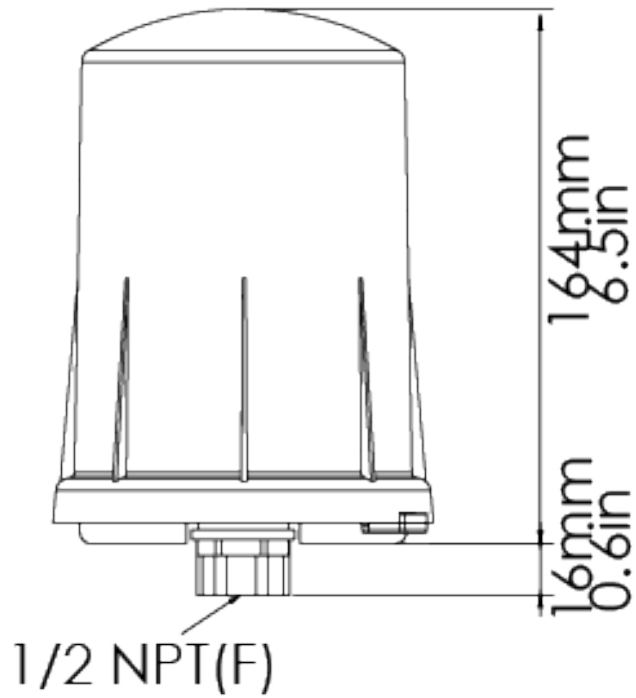

Bottom view

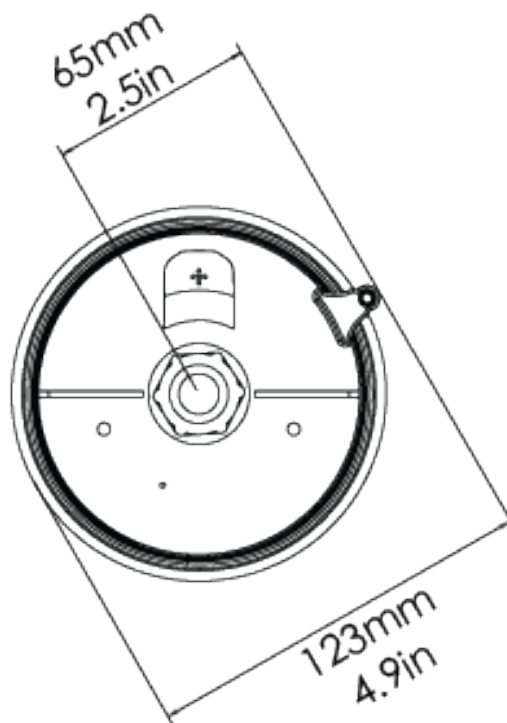

Connections and Components

Status LED

The Status LED (green) will flash 3 times on a successful data transmission to the server.

Error LED

The Error LED (red) will blink 3 times to indicate that an attempted data transmission failed.

Check-in Button

If this button is pressed the MyDro 54 will blink the green Status LED or the red Error LED 3 times to indicate the status of the last transmission to the server. If the check-in button is pressed and held for more than 1 second, the MyDro 54 will take readings from the attached sensors and send the readings to the server.

MyDro 54 Internal Components

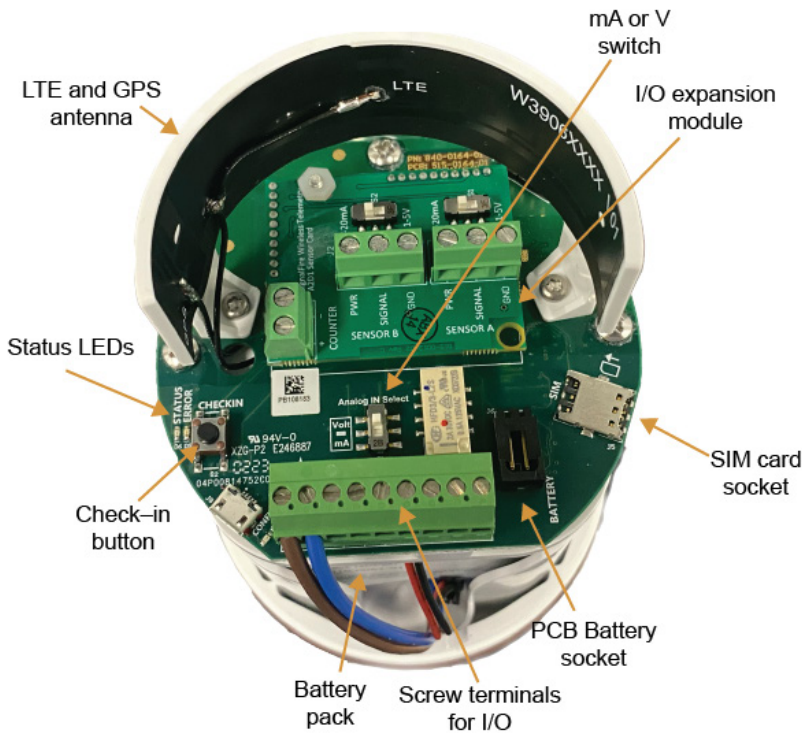

Sensor Connections

Analog Input



Screw Terminal Connections

The analog input provides 13V or 18V to the attached sensor. The analog input can operate in either current (4–20mA), or voltage (0–5V). The input mode must be set by the mA or V Switch. Slide the switch up to Volts for a voltage input, or down to mA for a current input.

4–20mA Wiring Diagram

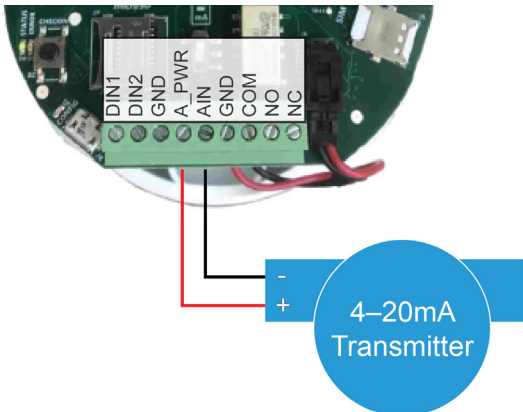

Sensor powered by MyDro

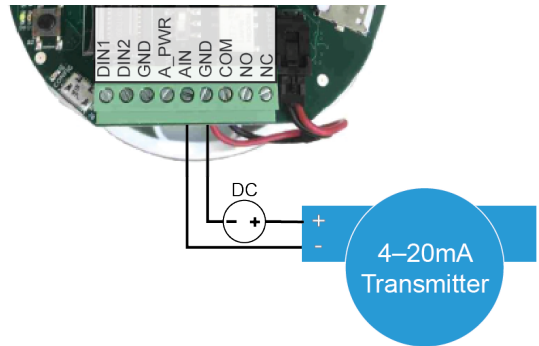

Sensor powered by external source

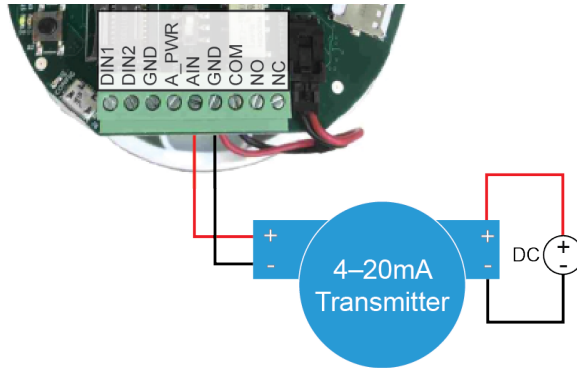

Sensor Setup in Active Loop

0–5V Wiring Diagram

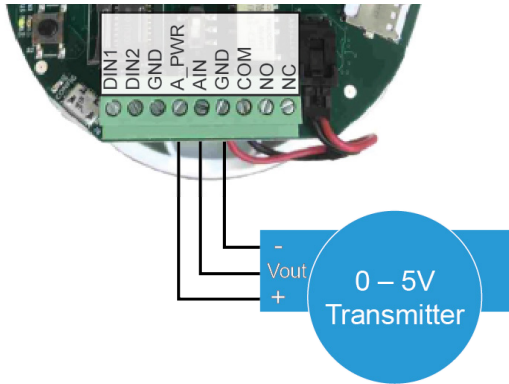

Digital Inputs

The built-in digital inputs (2 total) can be dry contact or voltage (must be push-pull, 30Vdc max). Be sure to connect the ground bus from the module to either the ground of the voltage pulse device or the dry contact.

Relay Output

The MyDro 50 has a single latching SPDT relay which may be controlled remotely from the server or by using the MyDro 54 internal relay control logic. The relay will connect the COM terminal to NC when de-energized and the COM will be connected to the NO terminal when energized.

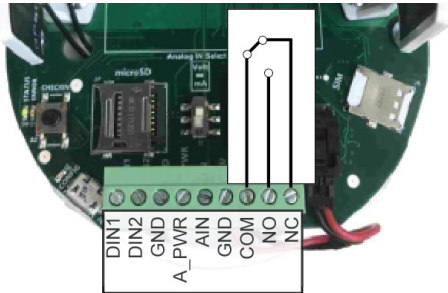

Relay de-energized (COM connected to a NC)

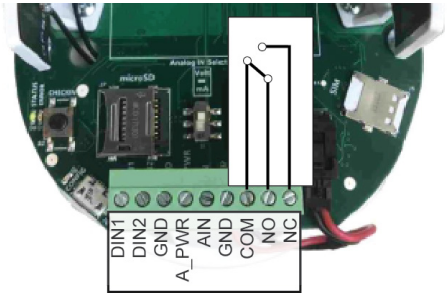

Relay energized (COM connected to NO)

Expansion Card



The MyDro 54 expansion card provides analog inputs 2–3 and digital input 3. These inputs operate the same as the onboard analog and digital inputs. The analog inputs can be set to 4–20mA mode or 0–5Vdc mode via onboard switches. When installed, additional input configuration tiles will become available on 123SCADA.

Power Options

Lithium Battery Pack (4DPak)

The internal lithium battery pack is the default power source for the MyDro 50. Simply plug the battery pack into the PCB battery connector to power the MyDro 54 on.

Internal Lithium Battery Replacement

Battery packs can be changed with the MyDro 54 in place.

1. Unscrew the cover from the base.
2. Unplug the battery from the PCB by depressing the locking clip on the connector.
3. Loosen the three screws that attach the circuit board assembly to the base. Do not remove the two screws that attach the antenna assembly.
4. Remove and replace the battery.
5. Reinstall the circuit board assembly. Do not over tighten these screws.
6. Connect the battery to the main PCB battery connector.
7. Install the enclosure cover.

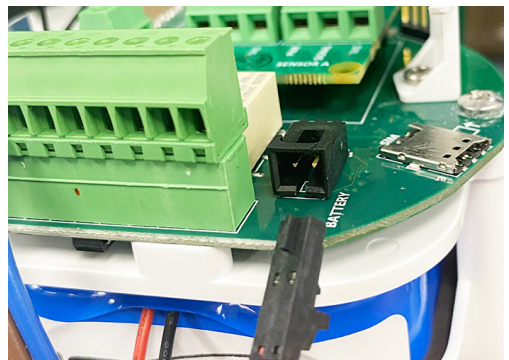

Mounting and Care

The MyDro 54 unit comes with an integrated cord grip with leads for connection to the sensors. It is important to mount the MyDro 54 vertically, with the NPT fitting facing down.



Test the Installation

Test that alarm notifications are received so they can be acknowledged by the customer or end-user once the unit is put into production. This includes phone numbers, SMS text messages, and email addresses.

Additionally, the customer or end-user should test all alarms every six months to ensure all electrical components and alarm parameters are still functioning as desired and that alarms are being received and acknowledged by recipients. Refer to the Spring Cleaning/Fall Fix-up document for testing procedures.

Complete the following tests prior to leaving the job site:

1. Test the battery and confirm that the MyDro 50 is powered and on line.
2. Test the radio connection. Check the status LED and ensure that it flashes 3 times upon a successful transmission. If it blinks red or not at all, call Technical Support at (877) 993-1911 option 2.
3. Test analog and digital inputs. Put each digital input into an alarm state and confirm that data is transmitted. Mission Technical Support is available to confirm that data is being properly transmitted and received on your web portal. A smartphone can be used otherwise.

Verify alarm notifications are received from the tests. Log on to your web portal with the credentials specified on the Notification Setup Form. Go to the Alarms page. You should see a list of alarm events with event time and the result.

Call Mission Technical Support after testing the installation to enable the device for alarm call-outs. A technician will verify proper operation of equipment. You may find it helpful to download the 123SCADA mobile application, available for free download on the Apple App Store and Google Play Store.

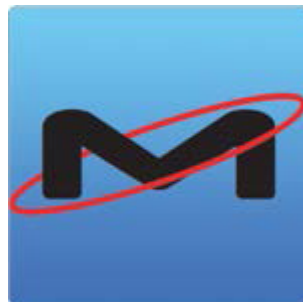

Site Commissioning

Confirm Paperwork and Credentials

Ensure that:

- Setup forms have been submitted to setupforms@123mc.com.
- Credentials have been received by the customer and they have proper login access and connectivity to the device. If it is a new customer they should have received a welcome email to establish access to 123SCADA Web portal.

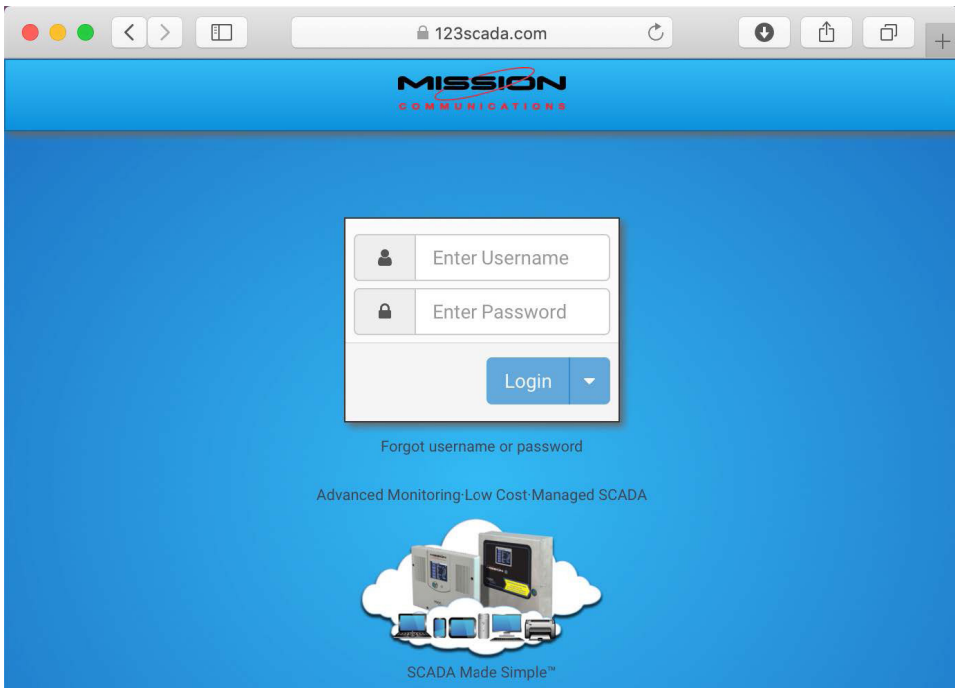

Log into 123SCADA Web Portal

Your unit is now ready for use. Visit 123scada.com and log in with your credentials to view your web portal.

Verify proper labeling on your web portal and MyDro 50 connections. Users with Superadmin or Admin credentials have the ability to make changes to the web portal.

Installation Notes

Support



Webinar

Mission hosts weekly webinars from 2–3 P.M. Eastern every Wednesday, except for weeks of national holidays and national trade shows. Staff members discuss the system hardware and software with live Q&A.



Video Demonstrations

A variety of videos are provided to cover topics relating to the MyDro 50 and the Mission system. These can be found on the 123SCADA web portal as well as the MyDro 50 product site on 123mc.com.



Documentation

Many documents are available through the web portal and marketing website which provide information about best practices, system troubleshooting, and more.



LinkedIn

Current product and company updates such as product releases, trade show appearances, and webinar schedules are regularly posted on LinkedIn so please connect with us. We also repost customer and partner posts.



X (Formerly Twitter)

Follow @123mc for notices about system enhancements, scheduled maintenance, and carrier issues. Download the mobile app and configure push notifications to receive immediate updates.

Technical Support
(877) 993-1911, option 2
techsupport@123mc.com,



Sales
sales@123mc.com
(877) 993-1911, option 4

M50NIM-2408