

## The Next Generation of Wireless Real-Time Alarm, Monitoring, and Remote Control

All of the functionality of the legacy series (M110 and M800) with an onboard interactive display and enhanced electronics

### MyDro 150 and 850 RTUs

#### Easy to Install

Each remote terminal unit (RTU) includes all necessary hardware for a standard installation, such as a cellular radio, enclosure, backup battery, transformer, antenna with cable, and mounting hardware. Purpose-built RTUs simplify and speed installation. There is no programming required, and RTUs are self-enrolling.

#### Reliable Wireless Communications

The RTU features a game-changing radio with an embedded SIM that supports multiple carriers (AT&T, T-Mobile, Verizon, and Telenor) as well as a removable SIM for future options such as FirstNet. That means access to multiple carriers is automatic with no need for a site visit to change a SIM. There are no radios to license, nor cellular contracts to set up.

#### Real-Time Alarms Delivered To All Devices

Real-time alarms are delivered via phone call, text message, email, fax, page, and even to an existing HMI software through an OPC data link. Each alarm is logged with a time stamp for tracking and reporting. The alarm call-out schedule is easy, flexible, and intuitive to set up.

#### Managed Service—The Complete Package

The Mission system includes all cellular data service, data storage, alarm callouts, reports, and on-call, 24-7-365 technical support. The highly reliable turnkey system offers more features at a lower cost than an in-house setup. No engineering or programming is required, and there are no networks to maintain.

View data and reports using the secure 123SCADA web portal, accessible from any web-enabled device. The 123SCADA user interface is designed to mimic industry-standard Human Machine Interface (HMI) Supervisory Control and Data Acquisition (SCADA) and also includes a legacy user mode. Tabular and graphical reports can be used for compliance reporting and comparative studies. System enhancements are available immediately and included at no cost.

### M150 RTUs

#### Real-Time Alarms with Hourly Summaries

M150 RTUs summarize pump runtimes and pump starts hourly. All alarm data is reported in realtime. Analog data and RTU status are reported hourly. Simultaneous pump runtimes can be reported when two pumps run.

### M850 RTUs

#### Real-Time Alarms and Streaming Data

M850 RTUs report pump starts and stops in real-time. Analog values are reported every two minutes or on a five percent change. Volumetric flow calculations can utilize this information along with sump volume (as determined by an analog level sensor or fixed entries) to calculate hourly volumetric flow rates.

#### Remote Control

Expand system operations with optional remote control for off-site wells, tanks, gates, chlorine dosers, variable frequency drives, and more. Optional automatic remote control interfaces include the Tank and Well Control Package, Digital Interconnect, and Analog Interconnect.



#### LCD Touch Screen

- Displays current status
- Supports local configuration

#### Radio

- Cellular radio supports multiple carriers to ensure optimal connection and signal quality
- No radio licenses or site path studies required

#### Expandable

- Up to 16 digital inputs, 6 analog inputs, 4 pulse inputs (with SMP), and 2 analog outputs, simultaneously
- Onboard digital inputs configurable for wire fault supervision or strap-on current sensing switch for easier pump run indication
- RS485 for digital, analog, and pulse expansion

#### Enhanced

- 12 or 24 VDC auxiliary output for battery-backed analog instrument loop power
- Over-the-air upgradeable firmware

	MyDro 150	MyDro 850
Wastewater	Duplex and triplex sewer lift station, industrial water quality (WQ) alarming, lift station generator alarming	Master pump station monitoring and remote control, critical process monitoring, open channel flow monitoring, sewer station power monitoring, reuse water monitoring and control
Water	Pump station alarming, reservoir level alarming, remote valve alarming, chlorine (Cl) residual WQ alarming, pressure reducing valve station alarming	Pump station monitoring, tank and multiple well control, remote valve monitoring and control, Cl residual WQ alarming, flow or pressure monitoring
Other	Gate status alarming, rainfall monitoring	Septic offload and billing, custody transfer and billing, canal level monitoring and gate control, I&I flow, level data logging

# Technical Specifications

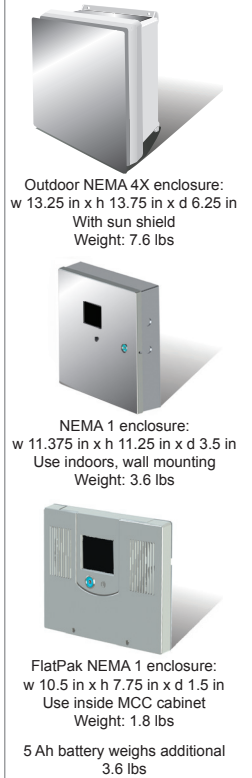
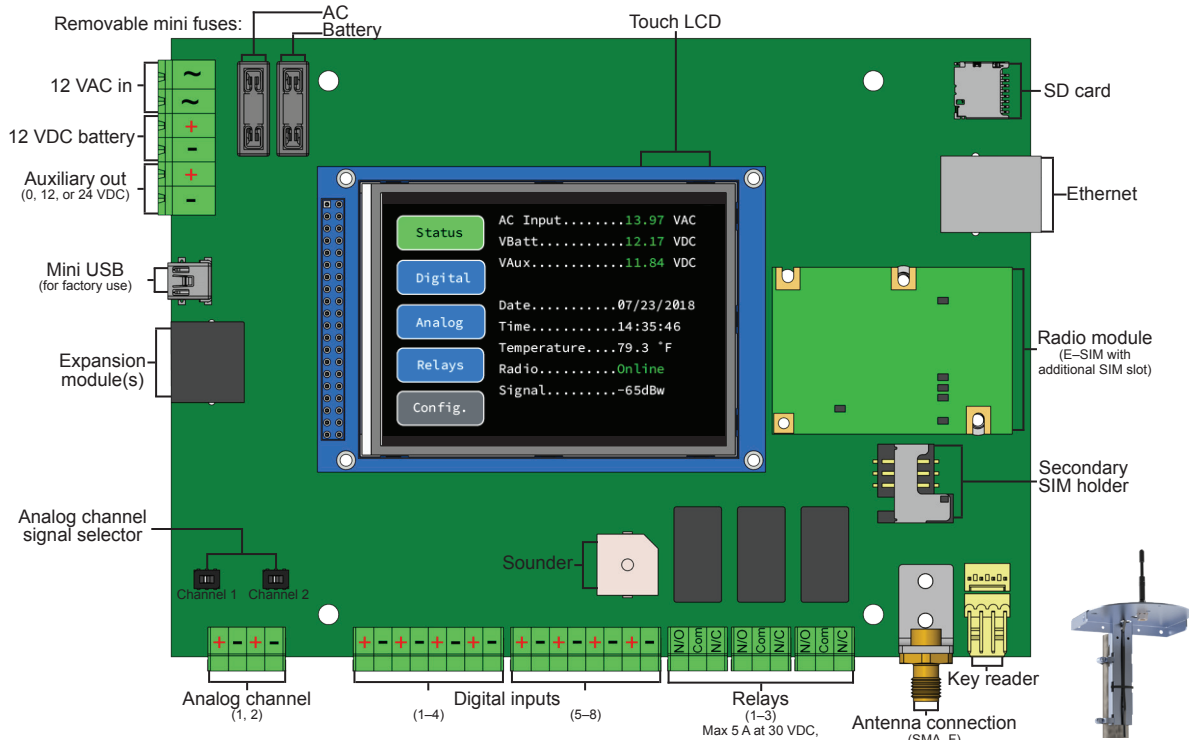

## MyDro 150

## MyDro 850

<b>Data</b>	<b>Alarm Data</b>	Real-time	Real-time
	<b>Pump State</b>	Summarized hourly	Real-time
	<b>Analog Reporting</b>	Current value reported hourly	Every 2 minutes or on 5% change
	<b>Device Health</b>	Built-in inputs reported hourly	
<b>Input/Output</b>	<b>Digital Inputs</b>	8 onboard, dry digital inputs with selectable wire fault supervision or direct attach current sensing switch; Expandable to 16 with PN OP653 3 configurable for pump run summary reporting; Simultaneous runtimes reported when 2 pumps are monitored	8 configurable for pump run; Pump states reported in real-time. Simultaneous pump runtime reporting supported for up to 7 pumps
	<b>Analog Inputs</b>	2 onboard, 4–20 mA isolated or 0–5 VDC; 4 alarm set points each; Expandable to 6 with PN OP465	
	<b>Relay Outputs</b>	3 remotely controllable, form C, dry contact relay outputs; 5 A at 30VDC, SPDT, N/O, or N/C	
	<b>RS485</b>	Support for specified expansion modules	
	<b>Pulse Inputs</b>	4 channels with Safe Module Plus expansion module PN OP750	
		15-minute reporting	2-minute reporting
	<b>Analog Output</b>	2 channels (4–20 mA or 0–5 V) with PN OP461	
	<b>Electronic Key Reader</b>	Key reader for site activity tracking and service mode	
<b>Electrical</b>	<b>Built-in Inputs</b>	AC voltage, battery voltage, board temp, and signal strength; Optional second key reader	
	<b>AC Power</b>	Supervised 120 VAC to 12 VAC, 1.2 A, UL-recognized class II/class III transformer	
	<b>Backup Power</b>	12 V, 5 Ah battery standard with enhanced charging system	
		Up to 50 hours	Up to 18 hours
	<b>Auxiliary</b>	Auxiliary output selectable 12 VDC or 24 VDC for battery-backed analog instrument loop powering; 250 mA max	
	<b>Removable Terminals</b>	Included: Amphenol PN 20020008-G061B01LF (6 pin for power), 20020004-D081B01LF (D08, D04, D03 for I/O)	
	<b>Power Consumption</b>	4.2 W	
<b>Other</b>	<b>Enclosures</b>	FlatPak (PN M153), NEMA 1 (PN M151), NEMA 4X (PN M152), Large NEMA 4X (PN M152L)	FlatPak (PN M853), NEMA 1 (PN M851), NEMA 4X (PN M852), Large NEMA 4X (PN M852L)
	<b>Environment</b>	Operating temperature -20–60 °C, non-condensing	
	<b>Cellular Radio</b>	Radios make live, continuous, encrypted TCP socket connections; Payload is end-to-end acknowledged; Penta band (850, 900, 1700, 1900, 2100 MHz); AT&T and partners: LTE, HSPA+, 3G; Verizon and partners: LTE, EVDO, 1XRTT	
	<b>Antenna</b>	Omnidirectional antenna with 11 ft cable, SMA termination, universal mounting bracket	
	<b>Options</b>	Optional SCADA integration OPC link (PN SW586) to client/server HMI, Tank and Well Control Package (see Accessory Catalog for details)	
	<b>Service</b>	Requires Service Packages for the unit and optional expansion boards (see Accessory Catalog for details)	
	<b>Warranty</b>	One-year manufacturing and material warranty	



Safety Certified

**MISSION**  
COMMUNICATIONS

(877) 993-1911 • sales@123mc.com • 123mc.com

M150/M850-2309